

	<b>FDCI222</b>	<b>FDCH221</b>
<b>en</b>	Input module	Housing
<b>de</b>	Eingabebaustein	Gehäuse
<b>fr</b>	Interface d'entrées	Boîtier
<b>es</b>	Módulo de entrada	Carcasa
<b>it</b>	Modulo ingressi digitali	Contentitore
<b>tr</b>	Giriş modülü	Muhafaza

**en** Installation  
**de** Montage  
**fr** Montage  
**es** Montaje  
**it** Montaggio  
**tr** Kurulum

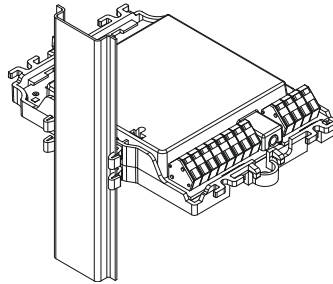

Fig. 1

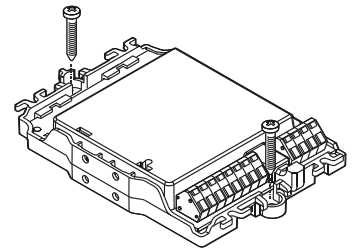

Fig. 2

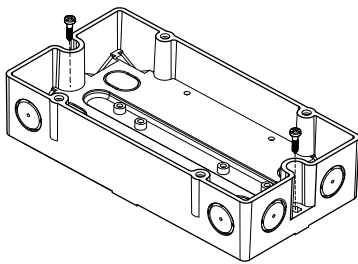

Fig. 3

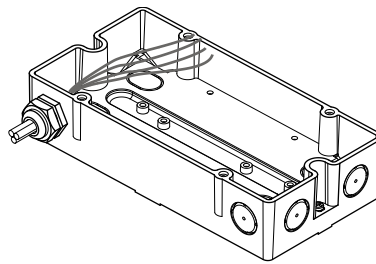

Fig. 4

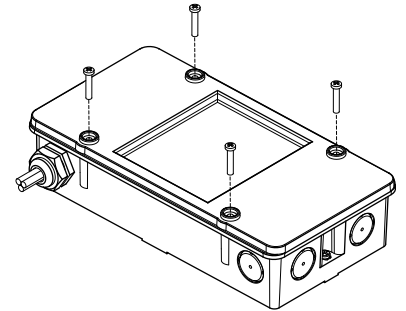

Fig. 5

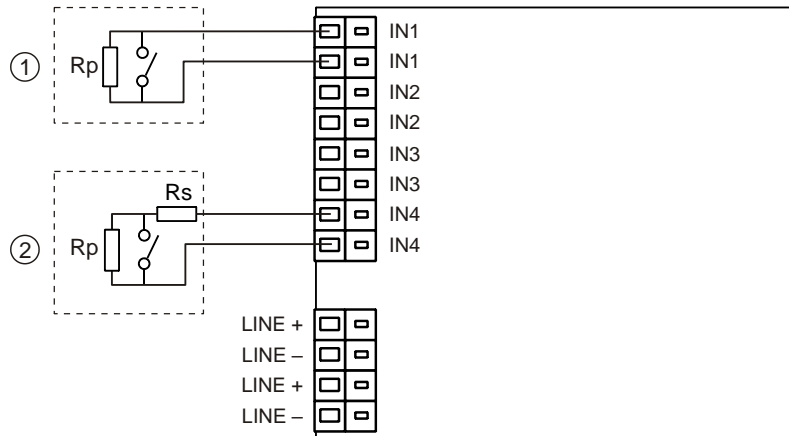

Fig. 6

	<b>en</b>	<b>de</b>	<b>fr</b>	<b>es</b>	<b>it</b>	<b>tr</b>
1	Monitoring only for open line	Überwachung nur auf Unterbruch	Surveillance d'interruption uniquement	Monitorización en cuanto a circuito abierto	Monitoraggio solo per interruzioni	Yalnızca açık hat için izleme
2	Monitoring for short-circuit and open line	Überwachung auf Kurzschluss und Unterbruch	Surveillance de court-circuit et d'interruption	Monitorización en cuanto a circuito abierto y cortocircuito	Monitoraggio per cortocircuiti e interruzioni	Kısa devre ve açık hat için izleme

**Intended use**

The input module monitors statuses of potential-free contacts. A housing is available to protect the module from environmental influences.

**Installing the input module**

The input module can be installed as follows:

- In housing FDCH221 (Fig. 5)
- On a top hat rail (Fig. 1)
- On a plane surface (Fig. 2)

**Installation in housing**

<b>!</b>	<b>NOTICE</b>
	<b>Module use in a damp, wet or dusty environment</b> Damage to module from dust or jet of water <ul style="list-style-type: none"> <li>• In damp, wet or dusty environments, fit the module in a housing FDCH221.</li> </ul>

1. Open housing (Fig. 5).
2. Determine cable entries in housing and break them open.
3. Use two screws to fit the housing on a plane surface (Fig. 3).
4. Secure the M20 x 1.5 cable glands on the housing and guide in the cables (Fig. 4).
5. Use two M3 x 12 screws to fit the module in the housing (Fig. 2).
6. Close housing using supplied screws (Fig. 5).

**Install input module on a top hat rail**

<b>!</b>	<b>NOTICE</b>
	<b>High temperatures in the module's environment</b> Module overheating and damage <ul style="list-style-type: none"> <li>• A minimum clearance of 1 cm must be observed between two modules or between the module and any other boundary.</li> </ul>

1. Insert two mounting feet into the input module.
2. Push the input module with the mounting feet against the top hat rail until the mounting feet engage (Fig. 1).

**Install input module on a plane surface**

<b>!</b>	<b>NOTICE</b>
	<b>High temperatures in the module's environment</b> Module overheating and damage <ul style="list-style-type: none"> <li>• A minimum clearance of 1 cm must be observed between two modules or between the module and any other boundary.</li> </ul>

1. Secure input module with two screws on a plane surface (Fig. 2).

**Electrical connection**

1. Connect the cables to the terminals (Fig. 6).

<b>i</b>	Note the positive and negative poles. Only connect one wire per terminal. This is the only way of ensuring a problem-free connection over the device's entire service life.
----------	---

2. If using shielded cables:
  - Use auxiliary terminals DBZ1190-AB (accessories) and connect shielding to auxiliary terminals. The shielding must not touch any extrinsic potentials to ground or metal parts in the device.
3. Connect resistors to input terminals according to planning:
  - Rp 3K01 line resistor
  - Rs 1K15 series resistor
 The resistors must be connected at the end of the line!
4. Secure cables on module with cable ties.

<b>i</b>	For more information see document 007023.
----------	---

## Verwendungszweck

Der Eingabebaustein überwacht Zustände von potentialfreien Kontakten. Für den Schutz vor Umwelteinflüssen steht ein Gehäuse zur Verfügung.

## Montage des Eingabebausteins

Der Eingabebaustein kann wie folgt montiert werden:

- Im Gehäuse FDCH221 (Fig. 5)
- Auf einer Hutschiene (Fig. 1)
- Auf einer planen Oberfläche (Fig. 2)

## Montage im Gehäuse

	<b>HINWEIS</b>
	<b>Einsatz des Bausteins in feuchter, nasser oder staubiger Umgebung</b> Beschädigung des Bausteins durch Staub oder Strahlwasser <ul style="list-style-type: none"><li>• Montieren Sie den Baustein in feuchter, nasser oder staubiger Umgebung in ein Gehäuse FDCH221.</li></ul>

1. Öffnen Sie das Gehäuse (Fig. 5).
2. Bestimmen Sie die Kabeleinführungen im Gehäuse und brechen Sie diese aus.
3. Montieren Sie das Gehäuse mit zwei Schrauben auf eine plane Fläche (Fig. 3).
4. Befestigen Sie die Kabelverschraubungen M20 x 1,5 am Gehäuse und führen Sie die Kabel ein (Fig. 4).
5. Montieren Sie den Baustein mit zwei Schrauben M3 x 12 im Gehäuse (Fig. 2).
6. Schließen Sie das Gehäuse mit den mitgelieferten Schrauben (Fig. 5).

## Eingabebaustein auf eine Hutschiene montieren

	<b>HINWEIS</b>
	<b>Hohe Temperaturen in der Umgebung des Bausteins</b> Überhitzung und Beschädigung des Bausteins <ul style="list-style-type: none"><li>• Zwischen zwei Bausteinen oder einer anderen Begrenzung muss mindestens 1 cm Freiraum vorhanden sein.</li></ul>

1. Stecken Sie zwei Montagefüsse in den Eingabebaustein.
2. Drücken Sie den Eingabebaustein mit den Montagefüssen gegen die Hutschiene, bis diese einrasten (Fig. 1).

## Eingabebaustein auf eine plane Oberfläche montieren

	<b>HINWEIS</b>
	<b>Hohe Temperaturen in der Umgebung des Bausteins</b> Überhitzung und Beschädigung des Bausteins <ul style="list-style-type: none"><li>• Zwischen zwei Bausteinen oder einer anderen Begrenzung muss mindestens 1 cm Freiraum vorhanden sein.</li></ul>

1. Befestigen Sie den Eingabebaustein mit zwei Schrauben auf einer planen Oberfläche (Fig. 2).

## Elektrischer Anschluss

1. Schließen Sie die Kabel an den Klemmen an (Fig. 6).



Beachten Sie die Plus- und Minus-Anschlüsse. Schließen Sie pro Klemme nur einen Draht an. Nur so kann ein störungsfreier Anschluss über die gesamte Lebensdauer des Gerätes gewährleistet werden.

2. Falls Sie Kabel mit Abschirmung verwenden:  
Verwenden Sie Zusatzklemmen DBZ1190-AB (Zubehör) und schließen Sie die Abschirmung an den Zusatzklemmen an. Die Abschirmung darf keine fremden Erdpotenziale oder Metallteile im Gerät berühren.
3. Schließen Sie entsprechend der Projektierung die Widerstände an den Klemmen der Eingänge an:
  - Rp 3K01 Linienwiderstand
  - Rs 1K15 SerienwiderstandDie Widerstände müssen am Ende der Leitung angeschlossen werden!
4. Befestigen Sie die Kabel mit Kabelbindern am Baustein.



Weitere Informationen siehe Dokument 007023.

**Application**

L'interface d'entrées surveille les états de contacts exempts de potentiel. Un boîtier est à disposition pour la protection contre les influences de l'environnement.

**Montage d'une interface d'entrées**

L'interface d'entrées peut être montée comme suit :

- Dans le boîtier FDCH221 (fig. 5)
- Sur un profilé (fig. 1)
- Sur une surface plane (fig. 2)

**Installation dans le boîtier**

<b>!</b>	<p><b>AVIS</b></p> <p><b>Utilisation du module dans un environnement humide, très humide ou poussiéreux</b></p> <p>Endommagement du module par la poussière ou les projections d'eau</p> <ul style="list-style-type: none"> <li>• Montez le module dans un boîtier FDCH221 en environnement humide, très humide ou poussiéreux.</li> </ul>
----------	--

1. Ouvrez le boîtier (fig. 5).
2. Déterminez les entrées de câbles dans le boîtier et dégagez-les.
3. Montez le boîtier sur une surface plane avec deux vis (fig. 3).
4. Fixez les presse-étoupe M20 x 1,5 sur le boîtier et introduisez les câbles (fig. 4).
5. Montez le module d'interface dans le boîtier avec deux vis M3 x 12 (fig.2).
6. Fermez le boîtier avec les deux vis fournies lors de la livraison (fig. 5).

**Monter une interface d'entrées sur un profilé**

<b>!</b>	<p><b>AVIS</b></p> <p><b>Températures élevées autour du module</b></p> <p>Surchauffe et endommagement du module</p> <ul style="list-style-type: none"> <li>• Il convient de toujours laisser un espace d'au moins 1 cm entre deux modules ou une autre délimitation.</li> </ul>
----------	---

1. Insérez deux ergots de montage dans l'interface d'entrées.
2. Poussez l'interface d'entrées avec les pieds de montage contre le profilé jusqu'à ce que les pieds s'enclenchent (fig. 1).

**Monter une interface d'entrées sur une surface plane**

<b>!</b>	<p><b>AVIS</b></p> <p><b>Températures élevées autour du module</b></p> <p>Surchauffe et endommagement du module</p> <ul style="list-style-type: none"> <li>• Il convient de toujours laisser un espace d'au moins 1 cm entre deux modules ou une autre délimitation.</li> </ul>
----------	---

1. Fixez l'interface d'entrées sur une surface plane à l'aide de deux vis (fig. 2).

**Raccordement électrique**

1. Raccordez les câbles aux bornes (fig. 6).

<b>i</b>	<p>Veillez à porter attention aux pôles positifs et négatifs.</p> <p>Ne raccordez qu'un fil par borne. C'est la seule manière de garantir un raccordement sans perturbation pendant toute la durée de vie de l'appareil.</p>
----------	--

2. Si vous utilisez un câble avec écran :  
Utilisez les borniers DBZ1190-AB (accessoires) et raccordez l'écran sur les borniers. L'écran ne doit être en contact avec aucun autre potentiel de terre ni aucune pièce métallique dans l'appareil.
3. Raccordez les résistances aux borniers des entrées (fig. 6 et fig. 7) selon la planification :
  - Résistance de ligne Rp 3K01
  - Résistance de série Rs 1K15

Les résistances doivent être raccordées à l'extrémité du câble !
4. Fixez les câbles sur le module d'interface avec des serre-câbles.

<b>i</b>	<p>Pour de plus amples informations, voir document 007023.</p>
----------	--

**Uso previsto**

El módulo de entrada monitoriza los estados de contactos sin potencial. Para la protección contra factores ambientales se dispone de una carcasa.

**Montaje del módulo de entrada**

El módulo de entrada puede montarse de la siguiente manera:

- En la carcasa FDCH221 (Fig. 5)
- En un carril DIN (Fig. 1)
- Sobre una superficie plana (Fig. 2)

**Montaje en la carcasa**

<b>!</b>	<p><b>AVISO</b></p> <p><b>Empleo del módulo en un entorno húmedo, mojado o polvoriento</b></p> <p>Daños en el módulo por polvo o chorros de agua</p> <ul style="list-style-type: none"> <li>• En un entorno húmedo, mojado o polvoriento, monte el módulo en una carcasa FDCH221.</li> </ul>
----------	--

1. Abra la carcasa (Fig. 5).
2. Determine las entradas de cable en la carcasa y rómpalas.
3. Monte la carcasa con dos tornillos sobre una superficie plana (Fig. 3).
4. Fije los prensaestopas para cable M20 x 1,5 en la carcasa e introduzca los cables (Fig. 4).
5. Monte el módulo con dos tornillos M3 x 12 en la carcasa (Fig. 2).
6. Cierre la carcasa con los tornillos suministrados (Fig. 5).

**Montar el módulo de entrada en un carril DIN**

<b>!</b>	<p><b>AVISO</b></p> <p><b>Altas temperaturas en el entorno del módulo</b></p> <p>Sobrecalentamiento del módulo y daños en el mismo</p> <ul style="list-style-type: none"> <li>• Entre dos módulos u otra limitación siempre debe haber un espacio libre mínimo de 1 cm.</li> </ul>
----------	--

1. Inserte dos pies de montaje en el módulo de entrada.
2. Presione el módulo de entrada con los pies de montaje contra el carril DIN hasta que encajen los pies (Fig. 1).

**Montar el módulo de entrada en una superficie plana**

<b>!</b>	<p><b>AVISO</b></p> <p><b>Altas temperaturas en el entorno del módulo</b></p> <p>Sobrecalentamiento del módulo y daños en el mismo</p> <ul style="list-style-type: none"> <li>• Entre dos módulos u otra limitación siempre debe haber un espacio libre mínimo de 1 cm.</li> </ul>
----------	--

1. Fije el módulo de entrada con dos tornillos en una superficie plana (Fig. 2).

**Conexión eléctrica**

1. Conecte los cables en los terminales (Fig. 6).

<b>i</b>	<p>Observe los polos positivos y negativos. Conecte únicamente un hilo por terminal. Sólo así podrá garantizarse una conexión sin fallos durante la vida útil completa del dispositivo.</p>
----------	---

2. Si utiliza cables apantallados:
  - Utilice terminales auxiliares DBZ1190-AB (accesorios) y conecte el apantallamiento en los terminales auxiliares. El apantallamiento no debe tocar ningún potencial de tierra externo ni piezas de metal en el dispositivo.
3. De acuerdo con la planificación, conecte las resistencias a los terminales de las entradas:
  - Resistencia de línea Rp 3K01
  - Resistencia serie Rs 1K15

¡Las resistencias deben conectarse en el extremo del cable!
4. Fije los cables con los sujetacables al módulo.

<b>i</b>	<p>Para más información, consulte el documento 007023.</p>
----------	--

**Destinazione d'uso**

Il modulo ingressi digitali monitora gli stati dei contatti a potenziale zero. Ai fini di protezione contro gli agenti ambientali è disponibile un contenitore.

**Montaggio del modulo ingressi digitali**

Ogni modulo ingressi digitali può essere configurato nel modo seguente:

- All'interno del contenitore FDCH221 (Fig. 5)
- Su guida a cappello (Fig. 1)
- Su una superficie piana (Fig. 2)

**Montaggio nel contenitore**

	<b>AVVISO</b>
	<b>Impiego del moduli in ambiente umido, bagnato o polveroso</b> Danneggiamento del modulo causato da polvere o getti d'acqua <ul style="list-style-type: none"><li>• In ambiente umido, bagnato o polveroso, montare il modulo in un contenitore FDCH221.</li></ul>

1. Aprire il contenitore (Fig. 5).
2. Individuare i punti di entrata dei cavi nel contenitore e aprirli.
3. Montare il contenitore con due viti su una superficie piana (Fig. 3).
4. Fissare i pressacavi M20 x 1,5 al contenitore e introdurre i cavi (Fig. 4).
5. Montare il modulo nel contenitore (Fig. 2) con due viti M3 x 12.
6. Fissare il contenitore con le viti fornite in dotazione (Fig. 5).

**Montare il modulo ingressi digitali su una guida a cappello**

	<b>AVVISO</b>
	<b>Temperature elevate nella zona del modulo</b> Surriscaldamento e danneggiamento del modulo <ul style="list-style-type: none"><li>• Tra due moduli o un'altra limitazione deve essere presente uno spazio libero di almeno 1 cm.</li></ul>

1. Inserire due piedini di montaggio nel modulo ingressi digitali.
2. Premere il modulo ingressi digitali unitamente ai piedini di montaggio contro la guida a cappello finché non scatta in posizione (Fig. 1).

**Montare il modulo ingressi digitali su una superficie piana**

	<b>AVVISO</b>
	<b>Temperature elevate nella zona del modulo</b> Surriscaldamento e danneggiamento del modulo <ul style="list-style-type: none"><li>• Tra due moduli o un'altra limitazione deve essere presente uno spazio libero di almeno 1 cm.</li></ul>

1. Fissare il modulo ingressi digitali su una superficie piana utilizzando due viti (Fig. 2).

**Collegamento elettrico**

1. Collegare i cavi ai morsetti (Fig. 6).

	Fare attenzione ai poli positivi e negativi. Collegare un solo filo per morsetto. Solo così può essere garantito un collegamento corretto durante l'intero ciclo di vita dell'apparato.
---	---

2. Se si utilizzano cavi con schermatura: utilizzare i morsetti ausiliari DBZ1190-AB (accessori) e collegare la schermatura ai morsetti ausiliari. La schermatura non può entrare in contatto con potenziali di terra esterni o parti metalliche all'interno dell'apparecchio.
3. Collegare le resistenze ai contatti degli ingressi conformemente alla progettazione:
  - Rp 3K01 resistenza di linea
  - Resistenza seriale Rs 1K15Le resistenze devono essere collegate all'estremità della linea!
4. Fissare i cavi sul modulo tramite fascette serracavi.

	Per ulteriori informazioni, vedere il documento 007023.
---	---

**Kullanım amacı**

Giriş modülü, potansiyelsiz kontakların durumlarını izler. Modülü çevresel etkilere korumak için bir muhafaza mevcuttur.

**Giriş modülünü takma**

Giriş modülü aşağıdaki gibi takılabilir:

- FDCH221 muhafaza içine (Şek. 5)
- Otomat rayının üzerine (Şek. 1)
- Düz bir yüzeye (Şek. 2)

**Muhafaza içine kurulum**

<b>!</b>	<b>NOT</b> <b>Nemli, ıslak veya tozlu bir ortamda modül kullanımı</b> Toz veya su püskürmesi nedeniyle modülde hasar <ul style="list-style-type: none"><li>• Nemli, ıslak veya tozlu ortamlarda modülü bir FDCH221 muhafazasına yerleştirin.</li></ul>
----------	---

1. Muhafazayı açın (Şek. 5).
2. Muhafazadaki kablo girişlerini belirleyin ve kırarak açın.
3. Muhafazayı düz bir yüzeye yerleştirmek için iki civata kullanın (Şek. 3).
4. M20 x 1.5 civatalı kabloları muhafazaya sağlamlaştırın ve kabloları geçirin (Şek. 4).
5. Modülü muhafazaya takmak için iki M3 x 12 civata kullanın (Şek. 2).
6. Verilen civataları (Şek. 5) kullanarak muhafazayı kapatın.

**Giriş modülünü bir üst raya takma**

<b>!</b>	<b>NOT</b> <b>Modül ortamında yüksek sıcaklıklar</b> Modül aşırı ısınma ve hasar <ul style="list-style-type: none"><li>• İki modül arasında veya modül ile diğer sınırlar arasında minimum 1 cm'lik bir boşluk bırakılmalıdır.</li></ul>
----------	---

1. Giriş modülüne iki montaj ayağı yerleştirin.
2. Giriş modülünü, montaj ayakları yerine oturana kadar montaj ayakları ile otomat rayına doğru itin (Şek. 1).

**Giriş modülünü düz bir yüzeye kurma**

<b>!</b>	<b>NOT</b> <b>Modül ortamında yüksek sıcaklıklar</b> Modül aşırı ısınma ve hasar <ul style="list-style-type: none"><li>• İki modül arasında veya modül ile diğer sınırlar arasında minimum 1 cm'lik bir boşluk bırakılmalıdır.</li></ul>
----------	---

1. Giriş modülünü iki civatayla düz bir yüzeye sabitleyin (Şek. 2).

**Elektrik bağlantısı**

1. Kabloları terminale (Şek. 6) bağlayın.

<b>i</b>	Pozitif ve negatif kutuplara dikkat edin. Terminal başına yalnızca bir kablo bağlayın. Cihazın tüm hizmet ömrü boyunca sorunsuz bir bağlantı sağlamanın tek yolu budur.
----------	---

2. Blendajlı kablolar kullanılıyorsa:  
DBZ1190-AB yardımcı terminallerini (aksesuarlar) kullanın ve blendajı yardımcı terminallere bağlayın. Blendaj, cihazdaki topraklama veya metal parçalara herhangi bir dış potansiyele dokunmamalıdır.
3. Resistörleri planlamaya göre giriş terminallerine bağlayın:
  - Rp 3K01 hat resistörü
  - Rs 1K15 serisi resistörResistörler hattın sonuna bağlanmalıdır!
4. Kabloları, kablo başlarıyla modüle sabitleyin.

<b>i</b>	Daha fazla bilgi için 007023 numaralı belgeye bakın.
----------	--

**FDCI222** A5Q00001984



**en** Input module  
**de** Eingabebaustein  
**fr** Interface d'entrées  
**es** Módulo de entrada  
**it** Modulo ingressi digitali  
**tr** Giriş modülü

**FDCH221** S54312-F3-A1

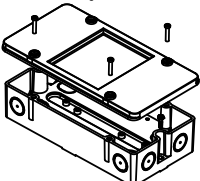

**en** Housing  
**de** Gehäuse  
**fr** Boîtier  
**es** Carcasa  
**it** Contenitore  
**tr** Muhafaza

**FDCM291** A5Q00003855

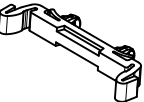

**en** Mounting foot  
**de** Montagefuss  
**fr** Pied de montage  
**es** Pie de montaje  
**it** Piedino di montaggio  
**tr** Montaj ayağı

--- A5Q00004478

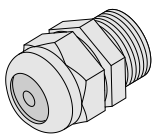

**en** Metal cable gland M20 x 1.5  
**de** Metall-Kabelverschraubung M20 x 1,5  
**fr** Presse-étoupe métallique M20 x 1,5  
**es** Prensaestopas metálico para cable M20 x 1,5  
**it** Pressacavo metallico M20 x 1,5  
**tr** Metal kablo rakoru M20 x 1.5

--- A5Q00004479

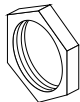

**en** Counter nut M20 x 1.5  
**de** Gegenmutter M20 x 1,5  
**fr** Contre-écrou M20 x 1,5  
**es** Contratuerca M20 x 1,5  
**it** Controdado M20 x 1,5  
**tr** Kontra somun M20 x 1.5

**DBZ1190-AB**

BPZ:4942340001

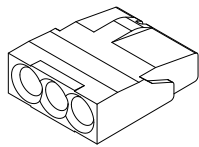
**en** Connection terminal 0.5...2.5 mm<sup>2</sup>**de** Verbindungsklemme 0,5...2,5 mm<sup>2</sup>**fr** Bornier 0,5...2,5 mm<sup>2</sup>**es** Terminal de conexión 0,5...2,5 mm<sup>2</sup>**it** Morsetto di collegamento 0,5...2,5 mm<sup>2</sup>**tr** 0,5...2,5 mm<sup>2</sup> bağlantı terminali

---

BPZ:2567860001

**en** Resistor Rp 3k01; 1 %; 0,25 W**de** Widerstand Rp 3k01; 1 %; 0,25 W**fr** Résistance Rp 3k01; 1 %; 0,25 W**es** Resistencia Rp 3k01; 1 %; 0,25 W**it** Resistenza Rp 3k01; 1 %; 0,25 W**tr** Resistör Rp 3k01; %1; 0,25 W

---

BPZ:3383580001

**en** Resistor Rs 1k15; 1 %; 0,25 W**de** Widerstand Rs 1k15; 1 %; 0,25 W**fr** Résistance Rs 1k15; 1 %; 0,25 W**es** Resistencia Rs 1k15; 1 %; 0,25 W**it** Resistenza Rs 1k15; 1 %; 0,25 W**tr** Resistör Rs 1k15; %1; 0,25 W



007023



siemens.com 



downloads.siemens.com



FDCI222



Issued by  
Siemens Switzerland Ltd  
Smart Infrastructure  
Global Headquarters  
Theilerstrasse 1a  
CH-6300 Zug  
Tel. +41 58 724-2424  
[www.siemens.com/buildingtechnologies](http://www.siemens.com/buildingtechnologies)

© Siemens Switzerland Ltd, 2007  
Technical specifications and availability subject to change without notice.